

Optical properties of X-rays – dynamical diffraction¹

André Authier

Received 5 September 2011

Accepted 29 September 2011

Institut de Minéralogie et de Physique des Milieux Condensés, Université P. et M. Curie, 4 Place Jussieu, F-75005, Paris Cedex 05, France. Correspondence e-mail: aauthier@wanadoo.fr

Dedicated to Max von Laue on the occasion of the hundredth anniversary of the discovery of X-ray diffraction.

The first attempts at measuring the optical properties of X-rays such as refraction, reflection and diffraction are described. The main ideas forming the basis of Ewald's thesis in 1912 are then summarized. The first extension of Ewald's thesis to the X-ray case is the introduction of the reciprocal lattice. In the next step, the principles of the three versions of the dynamical theory of diffraction, by Darwin, Ewald and Laue, are given. It is shown how the comparison of the dynamical and geometrical theories of diffraction led Darwin to propose his extinction theory. The main optical properties of X-ray wavefields at the Bragg incidence are then reviewed: *Pendellösung*, shift of the Bragg peak, fine structure of Kossel lines, standing waves, anomalous absorption, paths of wavefields inside the crystal, Borrmann fan and double refraction. Lastly, some of the modern applications of the dynamical theory are briefly outlined: X-ray topography, location of adsorbed atoms at crystal surfaces, optical devices for synchrotron radiation and X-ray interferometry.

1. X-rays as a branch of optics

[Laue's] discovery was primarily a contribution to optics.

(Sir C. W. Raman, 1937)

The title of this section is borrowed from that of A. H. Compton's Nobel lecture on 12 December 1927, in which he reviewed the main optical properties of X-rays studied at the time. Today, the applications of X-ray optics are widespread, ranging from radiography and lithography to X-ray high-resolution imaging with synchrotron radiation and refractive and diffractive X-ray lenses, but the nature of X-rays was not immediately recognized. In his first communication to the Würzburg *Physikalisch-medicinische Gesellschaft*, W. C. Röntgen (1895) suggested 'a kind of relationship between the new rays and light' and wondered whether they were not longitudinal waves in the ether. In 1896, the impulse theory was put forward independently by E. Wiechert (1896), who assumed that Röntgen rays were impulses of electrodynamic waves of very high frequency, and by Sir G. G. Stokes (1896), who proposed that they were pulses of very short wavelength propagating in the ether. The same suggestion was made by J. J. Thomson (1898). Many experimenters tried to observe the optical properties of X-rays:

Refraction. The first thing Röntgen did after ascertaining that the rays penetrate matter and propagate in straight lines was to look for their eventual refraction through a prism. For

this, he used prisms of water between mica sheets, of aluminium and of rubber, but unsuccessfully (Röntgen, 1895). As soon as the news of his discovery was known, in early January 1896, many scientists started looking for the properties of the new waves. One was the future Nobel Prize winner, J. Perrin (1896, 27 January). Their attempts at observing refraction of X-rays directly remained unsuccessful for a long time, including those by another future Nobel prize winner, C. G. Barkla (1916), until the first successful observation, by A. Larsson, M. Siegbahn and I. Waller (Larsson *et al.*, 1924, 1925) with a glass prism, using a photographic method to observe the deviation of the X-ray beam. It was next observed by B. Davis and C. M. Slack (Davis & Slack, 1925) with a prism of copper and an ionization chamber and by the same authors with a prism of aluminium inserted in the path of the X-ray beam between the two calcite crystals of a double-crystal spectrometer (Davis & Slack, 1926). More sensitive versions of the latter experiment were developed much later, when highly perfect crystals became available, for instance by Okkerse (1963) and by Malgrange, Velu and Authier (Malgrange *et al.*, 1968). Entirely new possibilities have been offered by the X-ray interferometer (Bonse & Hart, 1965); see §5.8.

Another way to detect the refraction of X-rays is through the shift it induces in the Bragg peaks, as will be discussed in §4.

Specular reflection. Many scientists, starting with Röntgen himself (1896), looked for specular reflection of the new rays, but to no avail. The first to observe it was A. H. Compton (1922, 1923*a*), followed by Siegbahn & Lundquist (1923, quoted by Larsson *et al.*, 1925) and others.

¹This Laue centennial article has also been published in *Zeitschrift für Kristallographie* [Authier (2012). *Z. Kristallogr.* **227**, 36–51].

Diffraction by a slit. After several unsuccessful attempts, in particular by Röntgen (1898), the first, rather uncertain, results were obtained by H. Haga and C. H. Wind (Haga & Wind, 1899, 1902), who observed the broadening of the image of a slit due to diffraction. Their slit was wedge-shaped, with a width 2 to 14 μm , and the exposure time ranged from 30 to 200 h. They made a rough estimate of the X-ray wavelength from the broadening they observed, using ordinary diffraction theory, but the result varied depending on the position of the diffracting slit and on the conditions of the experiment. They arrived at values of the wavelength of the order of 0.13 Å. A. Sommerfeld (1900) recalculated it by considering the diffraction of a single impulse by a slit, and obtained a value of 1.35 Å.

B. Walter and R. Pohl (Walter & Pohl, 1908) were sharply critical of Haga and Wind's experiments; they didn't believe they showed any evidence of diffraction and asserted that their wavelength estimations were invalid. They repeated Haga and Wind's experiment with a perfected setup (Walter & Pohl, 1909) and came to the conclusion that there was no observable diffraction and that if the wave nature of X-rays was proved by other means, their wavelength should be smaller than 0.12 Å. Their photographs were nevertheless analyzed again very carefully by P. Koch (1912), at Sommerfeld's request, with an accurate optical microphotometer. From the broadening of the image of the slit, Sommerfeld (1912) recalculated the width of the X-ray impulses (or wavelength) to be 0.4 Å. The paper was submitted 1 March 1912!

Polarization. The first major discovery concerning the optical properties of X-rays is due to Barkla (1905), who discovered that the secondary X-rays are polarized. According to J. J. Thomson's theory, the succession of 'thin' and very intense electromagnetic pulses induces an acceleration of the motion of the electrons in the medium, which emit a secondary radiation (Thomson, 1903). This radiation is more intense in the direction perpendicular to the movement of the electron and vanishes in the direction parallel to it. The secondary beam is therefore expected to be plane polarized, and this can be observed by a variation with direction of the intensity of a tertiary beam. In Barkla's first experiment with gases, the tertiary beam was too weak to allow accurate measurement, but consideration of the method of production of the primary beam led him to think that the primary beam was partially polarized in a direction perpendicular to that of the propagation of the cathode rays (electrons). By analysis with an electroscop of the variation of intensity of the secondary radiation from that primary beam, Barkla could prove the polarization of the X-rays. He repeated the experiment with metals, and in that case the tertiary radiation was strong enough to be analyzed and to prove the polarization of the secondary rays (Barkla, 1906). Barkla's experiments clearly proved the transverse character of the X-ray pulses. Following Barkla's work in England, polarization was also the topic of a thesis in Munich, Germany, by one of Röntgen's students, E. Bassler (1909).

Derivation of X-ray wavelengths from the consideration of light quanta. Wien (1907) generalized Planck's radiation theory to X-rays. When cathode rays accelerated through a potential V are absorbed in the anode, the maximum energy they may transfer to the X-ray light quantum is

$$eV = (1/2)mv^2 = hc/\lambda,$$

where e is the charge of the electron, m is its mass, v is its velocity, c is the velocity of light and hc/λ is the energy associated to a light quantum of X-rays according to Planck's theory. Wien was in that way able to estimate the X-ray wavelength to be about 0.675 Å.

Quite independently, J. Stark (1907) reached a similar result, 0.6 Å, with similar arguments, in a short paper dedicated to the quanta elements and positive and negative electricity.

Diffraction by a crystal grating. W. Friedrich and P. Knipping's famous experiment following M. Laue's idea brought about a spectacular and decisive proof of the wave nature of X-rays (Friedrich *et al.*, 1912). The history of the discovery and its context are recalled with many unpublished details by Eckert (2012). It is also briefly reviewed in Kubbinga (2012). It is described in many writings, in particular by its main actors, Laue (1952*b*) and Ewald (1962); see also Hildebrandt (1993) and Authier (2012).

The absence of any refraction or specular reflection was a source of difficulties for the holders of the electromagnetic hypothesis. This had been immediately obvious to Stokes (1897), who assumed, as a possible explanation, that this was due to the fact that the new rays were 'an irregular repetition of isolated and independent disturbances'. For this reason, and because of the ionization properties of X-rays, similar to those of α - and β -rays, W. H. Bragg (1907) introduced a corpuscular hypothesis for the nature of X-rays, in the form of neutral pairs, rather than ether pulses. This led to a heated debate between him and Barkla. His first reaction to the Munich discovery was reserved (W. H. Bragg, 1912*a*, 24 October), and it is only after his son Lawrence's derivation of Bragg's law, in November 1912 (W. L. Bragg, 1913), that he came round reluctantly (W. H. Bragg, 1912*b*, 28 November). He nevertheless insisted that 'the properties of X-rays point clearly to a quasi-corpuscular theory.' 'The problem,' he added, 'is not to decide between the two theories, but to find one theory which possesses the capacities of both.' It is only after the discovery of the Compton effect (Compton, 1923*b*) and the formulation by L. de Broglie of the relations between the properties of light and those of the atom that the dual nature, corpuscular and wave, of X-rays was really understood. For a historical perspective of the wave-corpuscle dualism, the reader may consult Wheaton (1983).

2. Ewald's thesis

P. P. Ewald was born on 23 January 1888 in Berlin (Fig. 1). He began his higher education with a one-year stay in Cambridge, UK, in 1905. From there, he went to Göttingen, where he studied mathematics under D. Hilbert, and then to Munich to



Figure 1
Peter Paul Ewald (1888–1985). After Authier (2009).

follow A. Pringsheim's lectures. It is somewhat by chance that he attended A. Sommerfeld's hydrodynamics course. He was immediately attracted to the 'interplay between the mathematical formalism and the physical arguments' which was so vividly described by Sommerfeld and from then on 'his heart was set on Mathematical Physics' (Ewald, 1968). He started his thesis in 1910, submitted it on 16 February 1912 and defended it on 5 March of that year (Ewald, 1912). It was, however, only published four years later (Ewald, 1916*a,b*).

The topic he chose among the ten or twelve proposed by Sommerfeld was 'to find the optical properties of an anisotropic arrangement of isotropic resonators' (Ewald, 1962). One of the motives was to find whether a physical property could be directly related to the regular arrangement of space lattices. The starting point of Ewald's work was the study of M. Planck's and H. A. Lorentz's theories of dispersion; but these authors had considered amorphous media in which the dipoles are randomly distributed. Sommerfeld's idea had been to find whether the regular arrangement of the dipoles in a crystal would be at the origin of new dispersive and refractive properties (Ewald, 1962).

Ewald divided the problem into two parts, the first one about the propagation of waves in an infinite triply periodic assembly of dipoles, the second one about the reflection or refraction of an incident wave by a semi-infinite medium. In the first part (theory of dispersion), he considered the field generated by the dipoles when excited by a plane wave of frequency ν and unknown velocity (Ewald, 1916*a*). Each dipole is set in oscillation by that incoming field and emits a spherical wave. This wave, which Ewald calls a 'wavelet', propagates with the velocity of light, $c = \nu/k$ ($k = 1/\lambda$, wavenumber in vacuum), and contributes to the excitation of the other dipoles. The total wave propagating inside the crystal is the resultant of all these wavelets: it is what Ewald calls 'the optical field'. The balance between this optical field and the oscillations of the dipoles was called a *dynamical*

balance by Ewald (1979). Owing to this interaction with the dipoles, the phase velocity, v , of the resultant field differs from c . There appears therefore a refractive index, which is, as shown by Fresnel, the ratio of the velocities in the medium and in vacuum, $n = c/v = K/k$ ($K = n/\lambda$, wavenumber in the medium). The problem is therefore to find all possible values of n ; the relation between the wavelength and the frequency is called the *dispersion equation*. The calculation of the total field involved the transformation of the sum of the contributions of all the dipoles into a sum of plane waves, of wavevectors \mathbf{K} . That was very complicated at a time when Fourier transforms were not in use, and Ewald performed the integrations by the method of residues. A summary using Fourier transforms can be found, for instance, in Authier (2001).

In the second part (theory of refraction and reflection), Ewald (1916*b*) introduced the boundaries of the crystal and an incident wave. By a formal truncation to a half-space of the lattice sum of the radiating dipoles, he proved that the progressive wave which excites the dipoles in the crystal may be expressed as the sum of two terms, one propagating with velocity c and which cancels out exactly the incident wave and another one which satisfies the wave equation for propagation with velocity c/n . This is the so-called Ewald–Oseen extinction theorem (Bullough & Hynne, 1992), which was also proved by Oseen in 1915 for isotropic media. The idea was entirely new at the time and since Ewald wasn't absolutely sure of himself, he preferred to seek advice from Laue; that was in late January 1912 (Ewald, 1962). This is the famous question which led Laue to ask whether Ewald's theory would be valid for short wavelengths, and what was the order of magnitude of the distances between neighbouring dipoles. This was at the origin of Laue's portentous intuition. Laue, who had been asked by Sommerfeld to write an article on diffraction by gratings for the encyclopedia of mathematical sciences he was editing, immediately got the idea of the diffraction of X-rays by a crystal grating. That article was only published later and included a chapter on X-ray diffraction (Laue, 1915).

Ewald was successful in showing that his model fulfilled the laws of optics. He tested it, at P. Groth's suggestion, on an orthorhombic crystal, anhydrite (CaSO_4). He could prove that birefringence was qualitatively predicted by his model, but the quantitative agreement was poor, owing in part to the fact that the structure of anhydrite it was based on was not correct; he had used a *P* Bravais lattice while anhydrite has in fact an *A* lattice. This result did nevertheless confirm that the space-lattice hypothesis of crystals was highly probable.

3. The dynamical theory of diffraction

In the calculation by Laue (1912) of the intensity of the diffraction spots, the interaction between the diffracted waves and the medium is neglected; the amplitudes scattered by a three-dimensional array of scatterers are added as if the amplitude of the incident wave was the same for all the diffracting centers. This is the so-called kinematical or geometrical theory of diffraction. For an infinite thickness

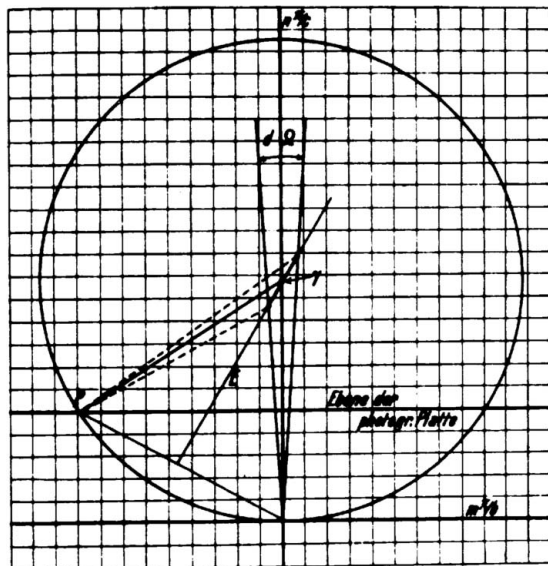

Figure 2
The reciprocal lattice and Ewald construction. After Ewald (1913).

of the diffracting medium, the diffracted intensity would tend towards infinity, which would violate the conservation of energy. It is only an acceptable approximation if the volume of the diffracting body is small, and because the diffracting amplitude of each scatterer is very small. The same approximation was made in the first of the two papers by C. G. Darwin (1914*a*). Following Lawrence Bragg's explanation of the diffraction mechanism by the interference of the waves reflected by a succession of equidistant planes (W. L. Bragg, 1913), Darwin added the amplitudes of the waves, simply taking their phase relationships into account.

What differentiates the dynamical theory is that it takes these interactions into account, as is done in any dispersion theory. The expression *dynamical theory of diffraction* was used for the first time by G. G. Stokes (1849), who treated the luminiferous ether as an elastic solid. He considered the diffraction of a wave by a slit and described as 'dynamical' the superposition of the secondary wavelets into which it is broken up according to Huygens' principle. It was used by Ewald in his thesis (Ewald, 1912) and was then extended to his theory of X-ray diffraction.

There are three forms of the dynamical theory of diffraction, by Darwin (1914*b*), by Ewald (1917, 1937), and by Laue (1931*a*, 1960). The roots of Ewald's theory lie in his thesis, but Laue (1931*b*) acknowledged Darwin's priority. The first extension to X-rays of his thesis was, however, made by Ewald as soon as he heard the news of the discovery of X-ray diffraction. This was during a seminar given in mid-June 1912 by Sommerfeld to the *Physikalische Gesellschaft*, in Göttingen, where Ewald was now physics assistant to D. Hilbert. It was at that time that the reciprocal lattice and the 'Ewald construction' were introduced, but the corresponding article was only published in 1913.

3.1. Ewald's 1913 paper and the reciprocal lattice

In his thesis, Ewald had described the optical field by the Hertz potential and showed that it can be expressed as a sum of plane waves. If one assumes the refractive index to be exactly 1, it is proportional to, using modern notation,

$$\sum_{\mathbf{h}} \frac{\exp(-2\pi i \mathbf{K}_{\mathbf{h}} \cdot \mathbf{r})}{K_{\mathbf{h}}^2 - k^2} \quad (1)$$

with $k = 1/\lambda$. Its wavevectors, $\mathbf{K}_{\mathbf{h}}$, are related to one another by

$$\mathbf{K}_{\mathbf{h}} = \mathbf{K}_0 - \mathbf{h}, \quad (2)$$

where \mathbf{K}_0 is a particular wavevector,

$$\mathbf{h} = h \frac{\mathbf{a}}{a^2} + k \frac{\mathbf{b}}{b^2} + l \frac{\mathbf{c}}{c^2}$$

and \mathbf{a} , \mathbf{b} , \mathbf{c} define an orthorhombic lattice. Ewald called the lattice defined by the vectors \mathbf{a}/a^2 , \mathbf{b}/b^2 , \mathbf{c}/c^2 the reciprocal lattice (*reziprokes Gitter*). He distinguished two cases: (1) the optical case, where $k = 1/\lambda$ is much smaller than the unit vectors of the reciprocal lattice and one term only in the sum (1) has a non-negligible amplitude; and (2) the X-ray case, where several terms may have a non-negligible amplitude, those corresponding to the resonances, for which $K_{\mathbf{h}}$ is not very different from k . Ewald expressed this condition geometrically by means of the construction that bears his name: there are as many waves with a non-negligible amplitude as there are reciprocal-lattice points close to the diffraction sphere (Fig. 2). With the assumption that the refractive index is equal to just 1, the condition is strictly equivalent to Bragg's law.

Ewald's definition of the reciprocal lattice was only valid for an orthorhombic lattice. It is Laue (1914) who generalized it to any type of symmetry, making use of the definitions by J. W. Gibbs (1881). At the time, Laue seems to have been unaware of the 'polar lattice' introduced by A. Bravais (1850, 1851) more than half a century before to facilitate crystallographic calculations, and which is homothetic to the reciprocal lattice. Laue (1960) acknowledged it later, however.

3.2. Darwin's theory – 1914

C. G. Darwin, the grandson of the father of the theory of evolution, Charles Darwin, was born on 18 December 1887 in Cambridge, England (Fig. 3). He graduated from Trinity College, Cambridge, in 1910, and immediately got a post-graduate position as reader in Mathematical Physics, Manchester Victoria University, with E. Rutherford. In 1912, his interests shifted towards X-rays, and, together with H. G. J. Moseley, another of Rutherford's co-workers, he started studying the reflected beam with an ionization chamber (Moseley & Darwin, 1913*a*, 30 January). At about the same time, W. H. Bragg (1913, 23 January) showed that the reflected beams had the same ionization properties as the primary beam. Moseley and Darwin chose the reflection setting, rather than the transmission one as Laue had done, because W. L. Bragg (1912, 12 December) had just before obtained intense



Figure 3
Charles Galton Darwin (1887–1962) Source: Wikicommons.

reflection spots from a sheet of mica. They observed intense reflections from crystals of gypsum and rock salt, and, at the suggestion of the Braggs (Bragg & Bragg, 1913), interpreted them as coming from the characteristic lines of the platinum target of their X-ray tube (Moseley & Darwin, 1913*b*). They made careful measurements of the positions and intensities of these selective reflections. These studies led Moseley and Darwin on different paths. The former went on to determine the wavelengths of the characteristic lines of the elements and to lay the bases of X-ray spectroscopy, to be stopped by his untimely death in 1915 in the Dardanelles battlefield during the First World War. The latter developed the theory of diffraction.

3.2.1. Geometrical or kinematical theory of diffraction. In the first of his two papers, Darwin (1914*a*) assumes that the scattering by one atom does not affect that by others (the so-called geometrical or kinematical approximation). He starts by calculating the amplitude reflected by one plane of atoms, using Fresnel zones. The complex reflection coefficient $-iq$ taking into account the phase shift associated with the scattering is

$$-iq = i \frac{Nd}{k \sin \theta} f(2\theta, k), \quad (3)$$

where $k = 1/\lambda$, N is the number of atoms per unit volume of the crystal, d is the distance between successive planes (Nd is the number of atoms per unit area of the diffracting plane), θ is the glancing angle and $f(2\theta, k)$ is the scattering amplitude of a single atom. Following J. J. Thomson (1903), and assuming the atom can be reduced to a point, $f(2\theta, k)$ is proportional to ne^2/mc^2 , where n is the number of electrons of the atom, and assuming one atom per unit cell. Actually, the scattering amplitude depends on the electron distribution around the atoms, a fact that was first recognized, independently, by W. H. Bragg (1915) and A. H. Compton (1915). It must also take into account all the atoms in the unit cell and

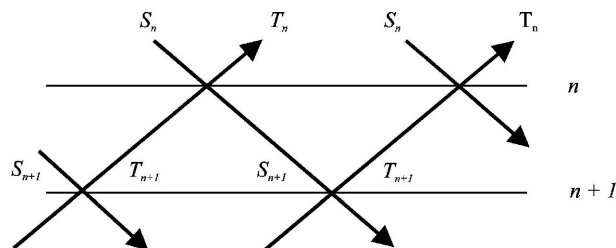

Figure 4
Darwin's dynamical theory. S_n : incident amplitude on plane n ; T_n : amplitude reflected from plane n . After Authier (2001).

$$f(2\theta, k) = RF_{hkl},$$

where F_{hkl} is the structure factor, and $R = e^2/mc^2$ is the so-called classical radius of the electron.

In the next step, Darwin summed up the amplitudes diffracted by the successive planes. The incident beam is in practice a divergent beam and the total reflected intensity is the result of an integration over the glancing angle (it is now called the integrated intensity). For a small non-absorbing crystal entirely bathed in the incident beam, and in the reflection geometry, it is given by

$$I_{\text{geom}} = I_o \frac{N^2 \lambda^3 R^2 |F_{hkl}|^2}{\sin 2\theta} \frac{1 + \cos^2 \theta}{2} \exp(-M) \Delta v = I_o Q \Delta v, \quad (4)$$

where $(1 + \cos^2 \theta)/2$ is the polarization factor, $\exp(-M)$ is the Debye factor taking thermal agitation into account (Debye, 1913), Δv is the volume of crystal and I_o is the energy incident per unit area in the beam. If the crystal is very large and absorbing, this expression is replaced by

$$I_{\text{geom}} = I \frac{Q}{2\mu}, \quad (5)$$

where μ is the absorption coefficient and $I = I_o S_o$ is the total energy of the incident beam (S_o is the cross section of the incident beam). The same results were obtained by Compton (1917) using a slightly different method of integration.

Darwin compared the calculated intensities with those measured with rock-salt crystals by Moseley & Darwin (1913*b*), and found them to be too large. He supposed that this was due to the assumption made in neglecting the interaction between the waves transmitted and reflected at each atomic plane, and he took them into account in the second of his papers (Darwin, 1914*b*), which is devoted to the dynamical theory of diffraction, although Darwin did not use that expression.

3.2.2. Theory of the reflection of X-rays by a perfect crystal. As the incident wave propagates inside the crystal, it generates both a reflected and a transmitted wave at each lattice plane it crosses (Fig. 4). These in turn generate reflected and transmitted waves whenever they cross an atomic plane, and so on. The amplitudes and phases of the transmitted and reflected waves are related, and this provides a set of recurrent

equations. Let S_n and S_{n+1} be the amplitudes of the waves incident on the n th and $(n + 1)$ th planes, respectively, and T_n and T_{n+1} be the amplitudes reflected from these planes. They are related by

$$\begin{aligned} S_n &= iqT_n + (1 - iq_o) \exp(-i\varphi)S_{n+1}, \\ T_{n+1} \exp(i\varphi) &= (1 - iq_o)T_n - iq \exp(-i\varphi)S_{n+1}, \end{aligned}$$

where $\varphi = 2\pi a \sin \theta / \lambda$ is a phase factor and q_o is the amplitude of the wave scattered in the forward direction. By solving this set of equations, it is possible to obtain the expression for the amplitude reflected at the surface of the crystal. Darwin showed that, if absorption is neglected, the amplitude is imaginary within a narrow angular range proportional to $|q|$; this is the domain of total reflection (see Fig. 5). Its width is

$$2\delta = \frac{NR\lambda^2 R|F_{hkl}|}{\pi \sin 2\theta} \quad (6)$$

and it is much narrower than the angular range of reflection given by the geometric theory; it is now called the *Darwin width*. In practice, crystals are always absorbing and the reflectivity is never 100%. The expression for the reflected intensity for absorbing crystals was first given by J. A. Prins (1930).

The centre of the total-reflection domain is shifted with respect to the Bragg angle by, in the symmetric reflection geometry (the only case considered by Darwin),

$$\Delta\theta = \frac{NR\lambda^2 F_o}{\pi \sin 2\theta}, \quad (7)$$

where F_o is the scattered amplitude in the forward direction. This shift is due to the effect of the refraction of the X-rays in the medium, as will be discussed in §4. The complete calculation with the dynamical theory shows that equation (7) should be multiplied by an asymmetry factor, which is equal to zero for a symmetric transmission geometry.

For a divergent incident beam, the intensity of the total reflected beam (integrated intensity) is given by

$$I_{\text{dyn}} = I_o \frac{8NR\lambda^2 |F_{hkl}|}{3\pi \sin 2\theta} \exp(-M) \frac{1 + |\cos 2\theta|}{2}. \quad (8)$$

This expression is very different from that given by the geometrical theory, equation (4). It is proportional to the absolute value of the structure factor and not to its square, it does not depend on the size of the crystal, and it is much smaller.

Darwin found that the reflected intensities calculated with equation (8) were not in better agreement with the experimental ones than those calculated from equations (4) or (5). This time, they were too small. This result was very baffling and Darwin attributed it to the presence of imperfections. He supposed that at various depths the crystal was twisted by an amount sufficient to allow a new reflection. One would therefore expect a wider angular range of reflection and a larger total reflected intensity. This was a first qualitative attempt at what would be the theory of extinction developed a few years later by Darwin (1922).

3.2.3. Extinction. The term ‘extinction’ was introduced by Bragg, James and Bosanquet (Bragg *et al.*, 1921a,b). They made very thorough measurements of the intensities reflected by crystals of rock salt, with the aim of determining its electron distribution and ascertaining whether the sodium atom had passed an electron over to the chlorine. They applied expression (5) given by the geometrical theory for the intensities and found that, at small glancing angles, one had to apply an anomalously large absorption coefficient. They attributed this to an ‘extinction’ effect due to the presence of imperfections.

This led Darwin to re-examine theoretically the reflection from crystals (Darwin, 1922). He was able to relate relations (4) and (8) and to show that, if the crystal is m lattice planes thick,

$$I_{\text{dyn}} = I_{\text{geom}} \frac{\tanh mq}{mq} \leq I_{\text{geom}},$$

where q is defined by equation (3).

For a thick perfect crystal (m large), equation (8) holds, while for a very thin perfect crystal (m small), it is equation (4)

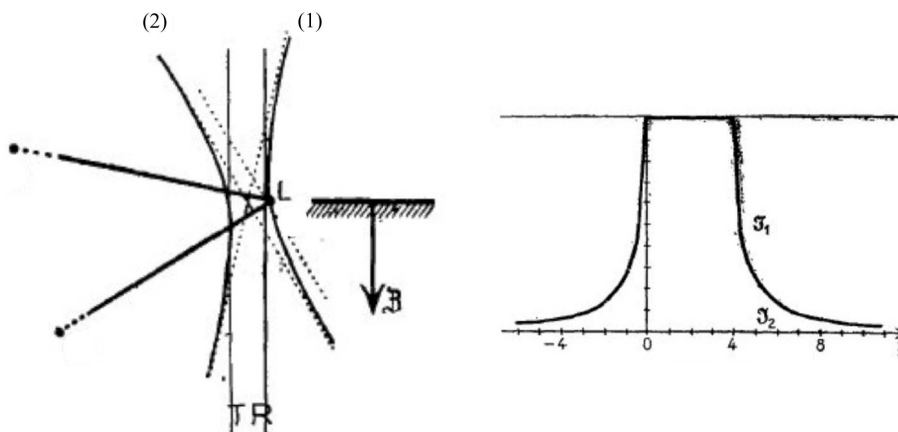

Figure 5 Reflection geometry. Left: dispersion surface. Right: total-reflection domain. After Ewald (1917).

which is valid. This suggested to Darwin a way out of the difficulty due to the disagreement between the experimental reflectivities and those calculated with either equation (4) or equation (8). He imagined the crystal to be a conglomerate of small blocks of perfect crystal [according to R. W. James (1962), the term 'mosaic crystal' is in fact due to Ewald]. Two situations may arise: the small blocks are not thin enough, their reflectivity becomes closer to that predicted by the dynamical theory; it must therefore be multiplied by a correction factor, which was called the *primary extinction* correction by Darwin. If the lattice planes in two successive blocks are nearly parallel, part of the incident intensity is reflected off by the first block before it reaches the second one. This is at the origin of the *secondary extinction* correction, which is taken into account by an artificial absorption coefficient.

The appropriate formulae to use for the reflected intensities were discussed during a conference organized by P. P. Ewald in Ammersee, Bavaria, in September 1925, and are reviewed in Bragg *et al.* (1926), where extinction is discussed in detail. Darwin's model is in reality too crude, and not applicable to most crystals. The problem of extinction remains acute even today, since it affects mainly the low-order reflections, which are particularly important for the determination of accurate electronic distributions. More and more sophisticated theories have been elaborated over the years, by such crystallographers as W. C. Hamilton, W. H. Zachariasen, P. Coppens, P. J. Becker and N. Kato.

3.2.4. Experimental study of reflection profiles – the double-crystal spectrometer. Typical widths of the total-reflection domain are of the order of a few arc seconds or less. Before synchrotron-radiation times, the divergence and spectral width of the incident beam, even after being monochromated by a preliminary reflection at a crystal surface, prevented the direct observation of reflection profiles. Davis & Stempel (1921) were the first to use a double-crystal setting using the same reflection on two identical crystals in the parallel, or (+, -), arrangement (Fig. 6). If ray 1 satisfies Bragg's condition on the first crystal for a given wavelength, λ_1 , and ray 2 for another wavelength, λ_2 , they both satisfy Bragg's condition on the second crystal: the setting is *non-dispersive* and the observed reflection profile is the convolution of the reflection profiles of the two crystals. Davis and Stempel used freshly cleaved calcite faces, but the angular widths of the profiles they observed were significantly larger than the theoretical ones according to equation (6). The first

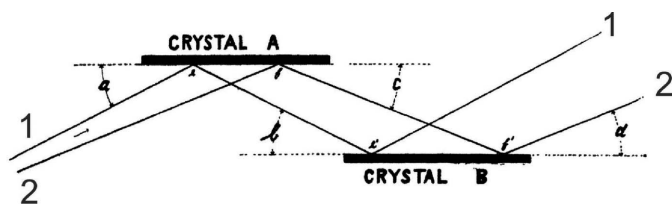

Figure 6 Double-crystal setting, parallel or anti-dispersive arrangement. After Davis & Stempel (1921).



Figure 7 Rocking curve obtained with a triple-crystal spectrometer; calcite, 211, Cu $K\alpha$. Reproduced from Renninger (1955).

person to observe profile widths which were very close to the theoretical values with a double-crystal spectrometer was Renninger (1934), who was at the time an assistant of Ewald's in Stuttgart. He used cleavage faces of rock salt for both crystals. The double-crystal method has been widely used, in particular in the design of monochromators. Modern monochromators are 'channel-cut', that is, the two crystals belong to the same single-crystal block of silicon or germanium.

In order to record intrinsic reflection profiles, the divergence of the incident beam must be smaller than the width of the profile. This was first achieved by Renninger (1955) using a triple-crystal spectrometer (Fig. 7) with three calcite crystals. It is now possible routinely with synchrotron-radiation techniques.

3.3. Ewald's theory – 1917

3.3.1. The dispersion surface. Ewald (1917) developed the dynamical theory of diffraction during World War I, while he was stationed on the Russian front, where he was servicing a mobile medical X-ray unit (Cruickshank *et al.*, 1992). The most important result of his dispersion theory is that the optical field is a sum of plane waves. The electric field deduced from the Hertz potential is

$$\mathbf{E} = \sum_{\mathbf{h}} \mathbf{E}_{\mathbf{h}} \exp(-2\pi i \mathbf{K}_{\mathbf{h}} \cdot \mathbf{r}) \exp(2\pi i \nu t), \quad (9)$$

where ν is the frequency of the waves and \mathbf{r} is a position vector. Expansion (9) was called a wavefield by Laue (1931a) and is sometimes called an *Ewald wave*. Solid-state physicists call it a Bloch wave, after Bloch (1928).

The wavevectors $\mathbf{K}_{\mathbf{h}} = \mathbf{HP}$, called *Anregungsvektoren* by Ewald, are vectors of the reciprocal space, where H is a reciprocal-lattice node, and they are related to one of them, $\mathbf{K}_0 = \mathbf{OP}$, by translations \mathbf{h} of the reciprocal lattice (Fig. 8, left):

$$\mathbf{K}_{\mathbf{h}} = \mathbf{HP} = \mathbf{K}_0 - \mathbf{h} = \mathbf{OP} - \mathbf{OH}, \quad (10)$$

where O is the origin of the reciprocal space, $\mathbf{K}_{\mathbf{h}} = \mathbf{HP}$ is the diffracted wave and $\mathbf{K}_0 = \mathbf{OP}$ is the incident wave. The joint extremity, P , of the wavevectors was called the *Anregungspunkt*, the excitation point, by Ewald (1917), but he later called it the 'tiepoint' to emphasize the link between the waves. Indeed, as we shall see, they propagate together in the

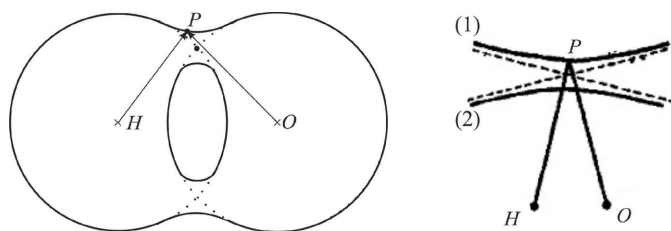

Figure 8
Ewald's dynamical theory – dispersion surface. Left: general view. After Authier (2001). Right: close-up view. Reproduced with permission from Ewald (1917). Copyright (1917) John Wiley & Sons.

crystal, generating standing waves, and have the same anomalous absorption properties.

The amplitudes of the waves are related to one another by, for a plane-polarized wave,

$$\mathbf{E}_h = \frac{K_h^2}{K_h^2 - k^2} \sum_{\mathbf{h}'} \chi_{\mathbf{h}'}' \mathbf{E}_{\mathbf{h}'}, \quad (11)$$

which expresses the self-consistency of the problem. The summation is over the reciprocal-lattice nodes and $\chi_{\mathbf{h}'}'$ is the h' coefficient of the Fourier expansion of the polarizability of the medium.

For the set of linear equations (11) to have a non-trivial solution, its determinant must be equal to zero. The corresponding secular equation is the dispersion equation. It is the equation of the surface on which the tiepoint P must lie, the *dispersion surface*.

The only terms in expansion (9) which have a non-negligible amplitude are those for which the resonance factors $1/(K_h^2 - k^2)$ are very large, namely those for which K_h is not very different from the wavenumber in vacuum, k . They correspond to the reciprocal-lattice points which are close to the Ewald sphere. Far from the Bragg condition for any reflection, there is only one such term, and one wave only propagates inside the crystal. Ewald limited himself to the two-beam case in which there are only two reciprocal-lattice nodes close to the Ewald sphere and two terms only in expansion (9), E_o and E_h . The dispersion surface is then composed of two sheets connecting the two spheres centred at O and H and of radii n/λ , where n is the refractive index (Fig. 8).

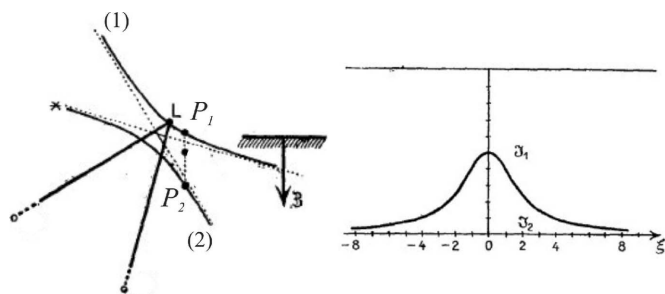

Figure 9
Transmission geometry. Left: dispersion surface. Right: reflection curve. Reproduced with permission from Ewald (1917). Copyright (1917) John Wiley & Sons.

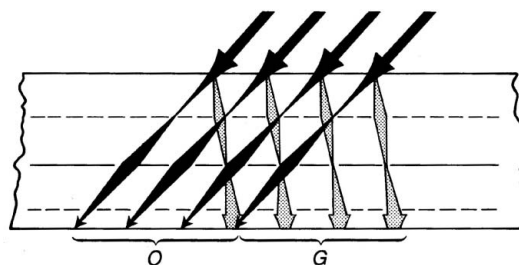

Figure 10
Plane-wave *Pendellösung* fringes as predicted by Ewald. After Ewald (1927). Courtesy Springer Science and Business Media.

3.3.2. Wavefields excited in the crystal by the incident wave – reflection profiles. The next step is to introduce the boundary conditions and find which are the waves actually excited in the crystal. The dispersion surface is the equivalent of the surface of indices in optics and one simply applies Huygens's construction. Two geometrical situations are to be distinguished: transmission, or Laue geometry, and reflection, or Bragg geometry.

Transmission geometry. Here the normal to the entrance surface of the crystal cuts across both branches of the dispersion surface (Fig. 9, left). There are two tiepoints, P_1 and P_2 , and two wavefields propagating inside the crystal. The boundary conditions are applied in the same way at the exit surface of the crystal to determine the reflected wave. The variations of its intensity with the glancing angle of the incident wave are shown in Fig. 9, right.

Reflection geometry: the normal to the entrance surface intersects one branch only of the dispersion surface (Fig. 5, left). The waves corresponding to the two points of intersection propagate, one downwards towards the inside of the crystal and the other one in the opposite direction. If the normal to the entrance surface lies between the positions R and T on the figure, the intersection points are imaginary and there is total reflection, as shown on Fig. 5, right, representing the variations of the reflected intensity with glancing angle of the incident wave. It is the famous 'top-hat' curve.

Twenty years after his main article, Ewald published a development of his theory for any kind of lattice and taking the full structure factor into account (Ewald, 1937).

3.3.3. Pendellösung. In the transmission geometry, the diffracted waves overlap as they propagate inside the crystal. The waves associated with the two branches of the dispersion surface interfere, and Ewald (1917) predicted that a periodic transfer of energy should occur between the waves diffracted in the incident and reflected directions, as shown in Fig. 10,

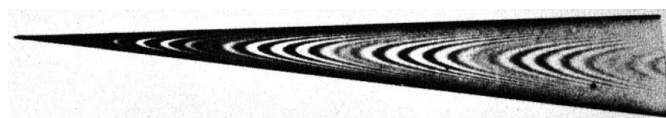

Figure 11
Hook-shaped *Pendellösung* fringes in a section topograph. Si, 220, $Mo K\alpha$. Courtesy N. Kato.

reproduced from a later publication (Ewald, 1927). He called this effect *Pendellösung*, after the German verb, *pendeln*, to oscillate. It took more than forty years until it was observed in real life, by Kato & Lang (1959) for spherical waves (Fig. 11) and by Malgrange & Authier (1965) in the plane-wave case. It is now commonplace and is also observed in the reflection geometry.

3.4. Laue's theory – 1931

Max von Laue was born on 9 October 1879 in Pfaffenheim, near Koblenz (Germany). He received his higher education at the universities of Strasbourg, Göttingen and Munich. He obtained his PhD in Berlin in 1903, prepared under the direction of M. Planck, and completed his *Habilitation* in 1906 under Arnold Sommerfeld in Munich. He then went back to Berlin as *Privatdozent* and assistant to Planck, and returned in 1909 to Munich, to the Institute of Theoretical Physics under Sommerfeld, where he conceived the 1912 experiment for which he was awarded the 1914 Nobel Prize in Physics (Fig. 12).

Laue admired Ewald's thesis and considered it one of the all-time *masterpieces* in mathematical physics (Laue, 1931a). He noted, however, that it represented crystals by a discrete distribution of single point dipoles, while the recent theories about the structure of the atom pointed to a continuous distribution of electronic charge, a view confirmed by the studies of Bragg *et al.* (1922) and James *et al.* (1928) on rock salt. This led him to reformulate the dynamical theory on an entirely different basis. He assumed a continuous distribution of the dielectric susceptibility of the medium for X-rays and considered it to be proportional to the electron density. A theory of the diffraction of X-rays by a medium with a continuous dielectric susceptibility had already been developed in Vienna by Lohr (1924), but it did not have any practical applicability.

Laue's theory is in fact simpler than Ewald's and is the more popular one. It consists of looking for solutions of Maxwell's equations in a medium with a triply periodic dielectric susceptibility. The electric negative and positive charges are distributed in a continuous way throughout the whole volume of the crystal, and cancel out so as to ensure the neutrality of the crystal. The local electric charge and density of current may therefore be put equal to zero in Maxwell's equations.

Laue finds it more convenient to represent the electromagnetic field through the electric displacement \mathbf{D} because $\text{div } \mathbf{D} = 0$. By elimination of the electric and magnetic fields in Maxwell's equation, one obtains the propagation equation,

$$\Delta \mathbf{D} + \text{curl curl } \chi \mathbf{D} + 4\pi^2 k^2 \mathbf{D} = 0. \quad (12)$$

The dielectric susceptibility χ can be expanded in a Fourier series:

$$\chi = \sum_{\mathbf{h}} \chi_{\mathbf{h}} \exp(2\pi i \mathbf{h} \cdot \mathbf{r}),$$



Figure 12

Max von Laue (1879–1960) Source: *Max von Laue – Biography*. Nobelprize.org.

where the coefficients $\chi_{\mathbf{h}}$ are proportional to the structure factor $F_{\mathbf{h}}$.

The electric displacement is therefore also triply periodic and can be expanded in a Fourier series analogous to (9),

$$\mathbf{D} = \sum_{\mathbf{h}} \mathbf{D}_{\mathbf{h}} \exp(-2\pi i \mathbf{K}_{\mathbf{h}} \cdot \mathbf{r}) \exp(2\pi i \nu t), \quad (13)$$

which expresses the wavefield propagating in the crystal.

By substitution of the expansions of χ and \mathbf{D} in the propagation equation (12), one finds that the amplitudes $D_{\mathbf{h}}$ satisfy a set of equations similar to (11), from which the dispersion surface is deduced in the same way.

In the 1931 article, Laue discussed the properties of the dispersion surface and derived expressions for the reflected intensity in both the transmission and reflection geometries, which are more convenient than Ewald's, but did not go further into the study of dynamical diffraction. A first extension of the theory was published after Laue had applied it to the explanation of the contrast of Kossel lines (Laue, 1941). A second edition of that book was published in 1945 with only small changes and a third, more developed edition, describing the propagation of wavefields inside the crystal and their anomalous absorption, appeared during the year of Laue's accidental death (Laue, 1960). An account of Laue's theory covering the progress that took place during the 40 years that followed can be found in Authier (2001).

Laue's theory of a continuous distribution of dielectric susceptibility was later justified quantum-mechanically by Moliere (1939a,b). The correspondence between Ewald's and Laue's dynamical theories was worked out by Wagenfeld (1968).



Figure 13
Norio Kato (1923–2002) in 1975. Courtesy B. Capelle.

3.5. Extension to spherical waves (Kato – 1960)

Darwin's, Ewald's and Laue's dynamical theories were valid for incident plane waves and perfect crystals. For that reason, they were difficult to verify experimentally, since beams from X-ray laboratory sources, however well collimated and monochromated, are never plane waves. The first person to extend the dynamical theory to spherical waves was N. Kato (Fig. 13). He expanded a spherical wave into plane waves by means of a Fourier transform, applied Laue's theory to each of these plane waves and then integrated the results over the whole width of the dispersion surface (Kato, 1960). He was inspired to do so by the observation of the hook-shaped fringes in Fig. 11 (see Authier, 2003). Kato's theory opened the way for more elaborate theories, such as S. Takagi's (Takagi, 1962, 1969), allowing for any type of incident wave and for the presence of defects in the crystals.

4. The refractive index of matter for X-rays

According to the dispersion theories available when the first hypotheses concerning the electromagnetic nature of X-rays were formulated, the refractive index was considered to be very close to 1 for very short waves (Lodge, 1896). The first person to have given an expression for the refractive index for X-rays was Darwin (1914a). His argument was as follows. If $-iq_o$ is the complex amplitude scattered in the forward direction by the first lattice plane, the amplitude of the incident wave on the second lattice plane is

$$A = (1 - iq_o) \exp(2\pi i vt) \frac{\exp(-2\pi i kr)}{r}. \quad (14)$$

One has, after crossing s planes,

$$\begin{aligned} A &= (1 - iq_o s) \exp(2\pi i vt) \frac{\exp(-2\pi i kr)}{r} \\ &\approx \exp(2\pi i vt) \frac{\exp(-2\pi i kr - iq_o s)}{r}, \end{aligned}$$

since $|q_o|$ is very small. Darwin remarked that the presence of the term $iq_o s$ implies a refractive index. If θ is the glancing angle and $z = sd = r/\sin\theta$ is the thickness of the crystal, taking the origin of the position vector \mathbf{r} at the entrance surface, one obtains for the transmitted amplitude

$$\exp(2\pi i vt) \frac{\exp[-2\pi i(k + q_o/d \sin\theta)]r}{r}$$

and, using equation (3),

$$(\exp 2\pi i vt) \frac{\exp(-2\pi i nkr)}{r},$$

where

$$n = 1 - \frac{RN\lambda^2 F_o}{2\pi} = 1 - \delta \quad (15)$$

is the refractive index, which is the result obtained far from an absorption edge with the dispersion theories of Lorentz (1916) and Ewald (1917). It is very close to 1; for instance, for silicon and Cu $K\alpha$, $n = 1 - 0.757 \times 10^{-5}$. The real and imaginary parts of δ close to an absorption edge were first calculated using quantum mechanics by H. Hönl (1933).

By comparing equations (7) and (15), it can be seen that the shift of the middle of the total-reflection domain with respect to the Bragg angle is related to the refractive index by

$$\Delta\theta = 2 \frac{\delta}{\sin 2\theta}. \quad (16)$$

This shift was first observed by W. Stenström (1919) in M. Siegbahn's laboratory in Lund University, Sweden, and in more detail by another student of Siegbahn's, E. Hjalmar (1920, 1923). They used a very accurate X-ray spectrograph developed by Siegbahn (1919) for the measurement of X-ray spectral lines. The observation came about from discrepancies in the values of the wavelength of Cu $L\beta_1$ deduced from Bragg's law, $nd = 2 \sin\theta$, for several orders of n in gypsum. The deviation from Bragg's law was suspected by W. Duane and R. A. Patterson (Duane & Patterson, 1920) with measurements of tungsten L lines with high-order reflections on calcite, but it lay within experimental errors. It was studied more fully in B. Davis's laboratory in Columbia University, New York, USA, first by Davis & Terrill (1922) with calcite and Mo $K\alpha_1$ and then, at B. Davis's suggestion, with crystals ground so as to give an asymmetric reflection, which increases the deviation, by Hatley (1924) with calcite, also with Mo $K\alpha_1$, and by Nardroff (1924) with pyrite and Mo $K\beta_1$, Cu $K\alpha_1$ and Cu $K\beta$.

It is Ewald (1920, 1924) who explained the shift by the effect of refraction and calculated it with the dynamical theory. It is rather surprising that no one mentioned Darwin's work at the time.

5. Optical properties of wavefields

The notion of wavefield was introduced initially as a purely mathematical entity: expression (9) describes the optical field in the crystal for Ewald (1913, 1917) and equation

(13) gives the solution of the propagation equation (12) for Laue (1931*a*). It does not appear in Darwin's theory. In fact, wavefields have a physical reality; the waves in a given wavefield undergo the same anomalous absorption (Borrmann, 1941, 1950), propagate along the same direction inside the crystal (Borrmann, 1954; Borrmann *et al.*, 1955), and the path of individual wavefields can even be isolated (Authier, 1960, 1961). The first evidence of the physical existence of the wavefields came from Laue's interpretation of the contrast of Kossel lines, based on the standing waves generated by the interference of the waves which constitute a wavefield.

5.1. Kossel lines

Kossel lines occur when the fluorescent radiation from one type of atom in a crystal is Bragg-reflected by the lattice planes of that same crystal. One speaks then of lattice sources (Fig. 14, left). The primary radiation maybe either electrons or X-rays. These lines lie at the intersections of cones having as axes the normals to each family of lattice planes with the photographic plate. As an example, the lines due to the reflections on $(\bar{1}11)$, $(1\bar{1}\bar{1})$ and $(1\bar{1}1)$ can be observed in Fig. 14, middle. These line are in general dark or light, or have a double contrast, dark–light or light–dark.

This effect was surmised by Clark & Duane (1923) and by Kossel (1924), but not explained by them. It was clearly observed for the first time in 1935, by Kossel and his co-workers using electrons as the primary source (Kossel & Voges, 1935; Kossel *et al.*, 1935). The Kossel lines, which are analogous to the Kikuchi lines observed in electron diffraction, were also studied in detail by G. Borrmann for his PhD thesis, prepared under the supervision of Kossel in Danzig (now Gdansk) – see Authier & Klapper (2007). He used X-rays as the primary source, both in the reflection setting (Borrmann, 1935, 1936) and in the transmission setting (Borrmann, 1938), and, like Kossel and his co-workers, a copper crystal as the source of the diffracted secondary radiation. It is interesting to note that W. Friedrich and P. Knipping had chosen a copper salt (copper sulfate pentahydrate) for their first attempts at observing diffraction of

X-rays by a crystal, the reason being that they believed it would have something to do with fluorescence radiation ('*Da wir anfangs glaubten, es mit einer Fluoreszenzstrahlung zu tun zu haben . . .*'; Friedrich *et al.*, 1912), and copper was a suitable element, according to Barkla.

Borrmann observed that, in the transmission geometry, the double contrast of the lines is inverse for thick crystals (Borrmann, 1938). This was not explained at the time but was, in fact, the first indication of anomalous absorption (Schülke & Brümmer, 1962).

It is Laue (1935) who explained the fine structure of the Kossel lines in the reflection geometry, using the properties of wavefields and the reciprocity theorem. The intensity of the wavefield excited by an incident plane wave is, after equation (13), in the two-beam case

$$|D(r)|^2 = |D_o \exp(-2\pi i \mathbf{K}_o \cdot \mathbf{r}) + D_h \exp(-2\pi i \mathbf{K}_h \cdot \mathbf{r})|^2. \quad (17)$$

Fig. 14, right, shows its variations across the reflection domain, in the reflection geometry. Laue (1935) argued that, according to the reciprocity theorem, the intensity distribution in space of the beams resulting from the reflection of the spherical waves emitted by the lattice sources should be identical. The fact that it is indeed what is observed was considered by Laue, at the time he was writing his 1960 book (1959), as the only direct evidence of the physical existence of the wavefields.

5.2. Standing waves

The intensity of a wavefield can be expressed from equations (17) and (10) by, in the two-beam case,

$$|D(r)|^2 = |D_o|^2 + |D_h|^2 + |D_o D_h| \cos(2\pi \mathbf{h} \cdot \mathbf{r} + \psi), \quad (18)$$

where ψ is the phase of D_h/D_o . Laue (1941) noted that expression (18) shows that the interference of the waves D_o and D_h generates a set of standing waves in the crystal. The term $\cos 2\pi(\mathbf{h} \cdot \mathbf{r} + \psi)$ indicates that the nodes lie on planes parallel to the lattice planes and that their periodicity is equal to $1/h = d_{hkl}/n$, where d_{hkl} is the periodicity of the hkl family of lattice planes and n is the order of the reflection. In transmission geometry, the phase ψ is equal to π for wavefields

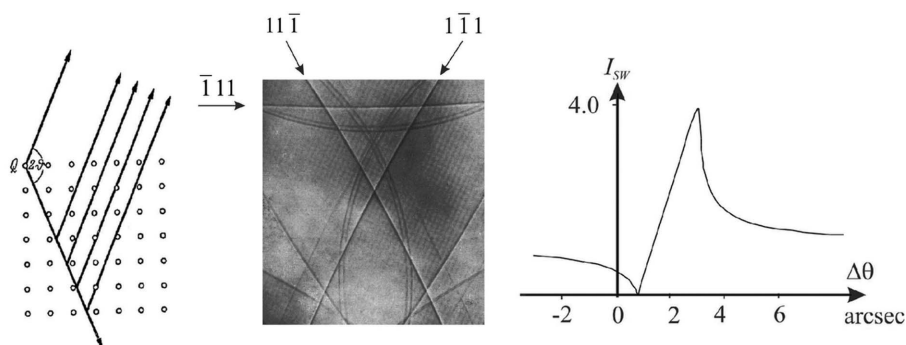

Figure 14

Left: Lattice sources. Reproduced with permission from Kossel & Voges (1935). Copyright (1935) John Wiley & Sons. Middle: Kossel lines in a copper crystal. After Voges (1936). Right: variation of the intensity of the wavefield $|D|^2$ across the reflection domain, recalculated after Laue (1935).

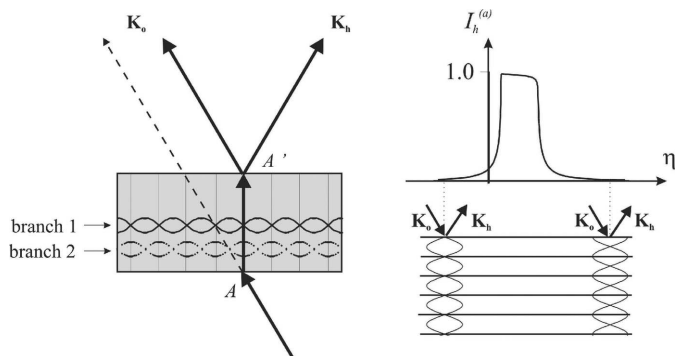

Figure 15
Position of the nodes and antinodes of standing waves. After Authier (2001). Left: transmission geometry. Right: reflection geometry.

associated with branch 1 of the dispersion surface and to 0 for wavefields associated with branch 2. The nodes of standing waves therefore lie on the lattice planes (planes of maximum electronic density) for a wavefield associated with branch 1 of the dispersion surface (Fig. 8) while it is the antinodes (maxima of electric field) which lie on the lattice planes for wavefields associated with the other branch of the dispersion surface (Fig. 15, left).

In reflection geometry, the phase ψ varies from π to 0 across the total-reflection domain. For an incidence on the low-angle side of the reflection domain, the nodes of standing waves lie on the lattice planes (Fig. 15, right). As the incidence sweeps the reflection domain, the nodes are progressively shifted until they lie midway between the reflecting planes for an incidence on the high-angle side of the reflection domain. It is the antinodes which then lie on the reflecting planes.

5.3. Anomalous absorption

Anomalous absorption of X-rays at a Bragg reflection is one of the most remarkable properties of wavefields. It was discovered by G. Borrmann (1941) and bears his name (*Borrmann effect*). Borrmann (Fig. 16) was born on 30 April 1908 in Diedenhofen (now Thionville, France). He received his higher education at the Technische Universität München and the Technische Hochschule Danzig (now Gdansk, Poland), where in 1930 he was awarded the title *Diplom-Ingenieur*, and where, as mentioned before, he obtained his PhD in 1936. In 1938, he was called by M. von Laue to the Kaiser-Wilhelm-Institut für physikalische Chemie and Elektrochemie in Berlin-Dahlem (now the Fritz-Haber-Institut der Max-Planck-Gesellschaft), where he turned to the study of reflection by perfect crystals.

It is to Borrmann and his students that we owe the first revival of the dynamical theory. When Ewald submitted his *Habilitation's* work in 1917, Sommerfeld found it a beautiful mathematical construction but predicted that it would never have any practical applications. These came more than 20 years later, with Borrmann's investigations.

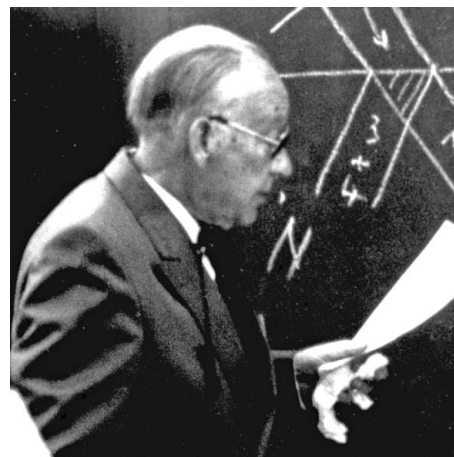

Figure 16
Gerhard Borrmann (1908–2006) in 1992. Reproduced with permission from Authier & Klapper (2007). Copyright (2007) John Wiley & Sons.

The discovery of anomalous absorption came from the observation by Borrmann of the forward-diffracted beams transmitted through good-quality crystals of calcite and quartz of various thicknesses, but only the quartz results were published at the time (Hildebrandt, 1995, 2002; Authier & Klapper, 2007). His experimental setup was the same as that already used by Rutherford & Andrade (1914) to measure the wavelength of γ -rays diffracted by a rock-salt crystal: a point source and a very divergent beam – the wide-angle method. The trace of the forward-diffracted beam was expected to show a deficit of intensity against the background because of the intensity drawn out of the incident beam by the reflected beam. It was the contrary that was observed, which baffled Laue considerably. It could only mean an anomalously low absorption. Laue (1949) accounted for the effect by calculating the intensities of the reflected and forward-diffracted beams taking absorption into account. Borrmann (1950, 1954) made very careful measurements of the anomalous absorption with calcite crystals and gave a very simple physical explanation: the nodes of the standing wavefields associated with branch 1 of the dispersion surface lie on the planes of maximum electronic density and there is minimum absorption (Fig. 15, left). Wavefields associated with branch 2 have their antinodes on these planes and are completely absorbed in thick crystals.

Anomalous absorption takes place in a similar way in the reflection geometry and is exhibited by the reflection profiles (Fig. 15, right). On the low-angle side, it is wavefields associated with branch 1 of the dispersion surface which contribute to the reflection and undergo little absorption. On the high-angle side, it is the wavefields associated with branch 2, and they undergo a larger absorption, hence the asymmetry in the reflection profile (Fig. 7 and top of Fig. 15, right).

5.4. Location of atoms at surfaces and interfaces

The shift of the system of nodes and antinodes in the reflection geometry when one rocks the crystal through the

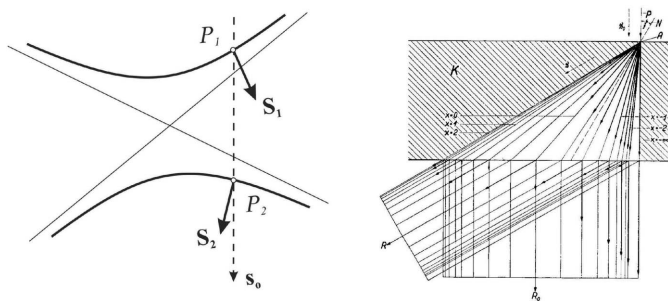

Figure 17
Propagation of wavefields in a crystal. Left: reciprocal space. \mathbf{s}_0 : normal to the crystal surface; P_1 , P_2 : tiepoints of the two waves excited in the crystal; \mathbf{S}_1 , \mathbf{S}_2 : Poynting vectors. Right: Borrmann fan in direct space. After Borrmann (1959a).

reflection domain (Fig. 15, right) can be made use of to localize the position of atoms in the crystal. If the incident radiation excites the emission of secondary radiation, either fluorescent X-rays or photoelectrons, by atoms of the crystal, this emission will be maximum when the atom lies at an antinode of the electric field. The position of these atoms can therefore be localized by detecting this secondary radiation with an appropriate detector synchronously with the recording of the intensity reflected by the crystal. From the orientation of the crystal when the secondary emission is excited, one can deduce the position of the atoms with respect to the lattice planes. The nature of the atom or impurity can be deduced from the analysis of this emission. The variation of the intensity of the wavefields through the total-reflection domain was first detected by B. W. Batterman (1964), using fluorescence scattering, and he suggested the application of this effect to the location of foreign atoms (Batterman, 1969). The technique has given rise to quite a new field for the study of impurities and adsorbed atoms at crystal surfaces, as well as for the determination of reconstructed crystal surfaces. For reviews, see, for instance, Zegenhagen (1993), Vartanyants & Koval'chuk (2001) or Authier (2001).

5.5. Path of the wavefields – Borrmann triangle, or fan

A surprising result of Borrmann's 1950 article had been that the propagation of X-rays in thick crystals was neither along the incident nor the reflected directions, but in between, along the lattice planes. This had already been guessed earlier, in a very qualitative way, by Murdock (1934), who had observed 'triple Laue spots' in quartz crystals. Laue had at first not been convinced by Borrmann's observations. But, from Maxwell's theory of electromagnetism, it is known that the direction of propagation of the energy of an electromagnetic wave is along the Poynting vector, $\mathbf{S} = \text{Re}(\mathbf{E} \wedge \mathbf{H}^*)$, where $\text{Re}(\mathbf{E})$ is the real part of \mathbf{E} and \mathbf{H}^* is the complex conjugate of \mathbf{H} . Laue (1952a) calculated the Poynting vector by means of the dynamical theory and showed that it is normal to the dispersion surface (Fig. 17, left). A natural incident beam is divergent and should therefore excite tiepoints along the whole dispersion surface. It is therefore to be expected

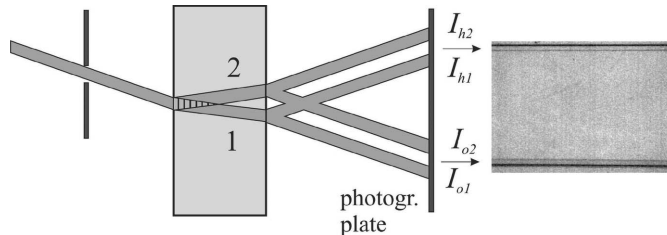

Figure 18
Experimental proof of the double refraction of X-rays in a silicon crystal. Left: experimental setup. Right: traces of the reflected and forward diffracted beams. After Authier (2001).

that there should be wavefields propagating inside the crystal along all the directions lying between the incident and reflected directions (Borrmann, 1954, 1959a). They fill out what is now called the *Borrmann triangle*, or fan (Fig. 17, right). The anomalous absorption is maximum for waves propagating along the lattice planes, and, for thick crystals, these waves are the only ones observed, as Borrmann (1950) had shown. The path of wavefields in a calcite crystal was then studied carefully by Borrmann *et al.* (1955), bringing the confirmation of Laue's calculations. That calculation was later generalized by Kato (1958) to the *n*-beam case. Ewald (1958) pointed out that Laue's and Kato's calculations implied incident plane waves, which was not the case in practice, and did not provide a physical description of the behaviour of the wavefields. He then proposed a very simple physical proof by substituting wave bundles for plane waves and showing that their group velocity is along the normal to the dispersion surface.

5.6. Double refraction

5.6.1. Paths of individual wavefields inside the crystal. An incident plane wave excites two wavefields inside the crystal in the transmission geometry, of tiepoints P_1 and P_2 (Fig. 17, left), and of Poynting vectors \mathbf{S}_1 , \mathbf{S}_2 . The two wavefields therefore propagate along separate paths inside the crystal. In the general case of unpolarized radiation, there are in fact four wavefields, two for each direction of polarization. This is why Borrmann (1955) spoke of quadruple refraction (*Vierfachbrechung*) of X-rays. In practice, the paths corresponding to the two directions of polarization are so close that it is hopeless to observe their separation. The separation of the paths of wavefields 1 and 2 is in principle also impossible to observe, since either the incident wave is a spherical wave and all the possible directions of propagation within the Borrmann fan are excited, or it is a plane wave and its lateral expansion is by definition infinite. The paths of the two wavefields then overlap and cannot be separated.

A way around this difficulty is by isolating from the Borrmann fan a wave packet which is narrow both in direct and reciprocal space (Authier, 1960). The paths of the two packets of wavefields, 1 and 2, can then be separated (Fig. 18, left). The result is shown in Fig. 18, right (Authier, 1961). It provides the

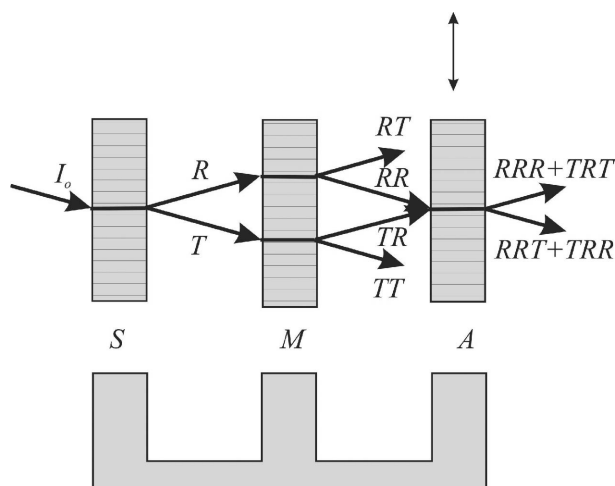

Figure 19
Principle of the LLL interferometer. *S*: splitter; *M*: mirror; *A*: analyzer. Bottom: side view. Top: top view. After Authier (2001).

most direct experimental proof of the physical existence of the wavefields.

5.6.2. Refraction of X-rays by a prism. If the crystal is a plane-parallel slab, the wavevectors of the forward diffracted waves outside the crystal are identical to that of the incident wave. However, if the exit surface of the crystal is not parallel to the entrance surface, as in a prism, the outgoing wavevectors will be different to the incident one. This was predicted by Laue (1940) and observed by Kohra *et al.* (1965).

5.7. Topography

The propagation of the wavefields within the Borrmann triangle is hampered by the presence of crystal defects. Borrmann could thus observe images of dislocation lines as shadows in the reflected and refracted beams for crystals with a large value of μt , where μ is the linear absorption coefficient and t is the crystal thickness (Borrmann *et al.*, 1958; Borrmann, 1959*b*). Dislocation images were also observed at the same time, independently, by A. R. Lang (1958) with less absorbing crystals, also by transmission, and by J. B. Newkirk (1958) and U. Bonse (1958) in reflection geometry. This was the birth of *X-ray topography*, a whole new field of investigations for all sorts of crystal defects besides dislocations: planar defects such as stacking faults, low-angle grain boundaries, twin boundaries, domains (ferroelectric, magnetic, ferroelastic...), precipitates, inclusions and microdefects, long-range defects and strain gradients, acoustic waves, and so on, with a very wide range of applications ranging from the characterization of growth defects to the study of the mechanisms of deformations and to the quality control of semiconductor, electro-optic or piezoelectric devices. For reviews, see, for instance, Klapper (1991), Authier *et al.* (1996), Bowen & Tanner (1998) and Authier (2001).

The characterization of the nature and the properties of the crystal defects requires a deep understanding of the mechan-

isms of the formation of their images, which relies on the application of the dynamical theory and its extensions to deformed crystals.

5.8. X-ray interferometry

X-ray interferometry is another very important application of the optical properties of X-rays at Bragg incidence. In its initial and simplest version (Bonse & Hart, 1965), two thick grooves are sawn out in a large, highly perfect single crystal of silicon, so as to obtain three coherent equally spaced crystal slabs connected by a common base (Fig. 19). The first slab, the splitter, *S*, splits the incident beam into two beams, *R* and *T*, which are transmitted in the reflected and incident directions, respectively. They are incident on the second crystal, the mirror, *M*, and give rise each to two beams, *RT* and *RR*, *TT* and *TR*, respectively. The beams *RR* and *TR* converge on the third slab, the analyzer, *A*. They are coherent and interfere, generating a set of standing waves which has the same periodicity as the lattice planes of the third slab. The intensities of the beams diffracted by the analyzer, *RRR* + *TRT* and *RRT* + *TRR*, depend on the position of the lattice planes of the analyzer with respect to the nodes of the standing waves. This position can be modified by translating the third slab along the direction of the arrow, which can be achieved by introducing a spring flexure between the second and the third crystal and pushing the last one by means of a piezoelectric drive. During this shift, the intensities *RRR* + *TRT* and *RRT* + *TRR* vary periodically. By measuring the translation of the crystal accurately and counting the fringes, one can make a direct measurement of the interplanar distance and obtain an absolute measurement of the X-ray wavelength. The shift of the respective positions of the set of standing waves and the lattice planes can also be obtained by putting a phase object in the path of the *R* beam between the first and second slab, thus allowing measurement of the index of refraction of the object (Bonse & Hellkötter, 1969; Creagh & Hart, 1970).

Interferometers of various designs have been built and have many applications for measurements of the index of refraction and phase-contrast studies, as well as in nanometrology for absolute measurements of lattice parameters, X-ray wavelengths or the Avogadro number. For a review, see, for instance, Authier *et al.* (1996).

6. Conclusion

The dynamical theory of X-ray diffraction was born out of an optics problem, Ewald's thesis in 1912. During its first stage of life, up to the mid-1930s, the main actors of which were Darwin, Ewald and Laue, its objectives were limited to the determination of the reflection profiles and integrated intensities of perfect crystals. Owing to a lack of crystals perfect enough to test the theory, it did not have any practical application, as Sommerfeld had predicted.

Borrmann's experimental observations of anomalous absorption and wavefield trajectories are at the origin of

dynamical theory's second stage of life. They induced Laue to make a theoretical study of anomalous absorption and of the propagation of wavefields in crystals. The importance of Borrmann's work was stressed by P. P. Ewald in the following words addressed to him during the celebration of his 65th birthday and reproduced in a special issue of *Zeitschrift für Naturforschung* (28a, 1973): 'Concepts such as wavefields and fans of rays have been awoken from the slumber of theory by your exemplary and cleanly conducted research and have been established into physical reality' (quoted in Authier & Klapper, 2007).

The availability in the late 1950s of highly perfect silicon and germanium crystals enabled experimental verifications of theoretical predictions to become possible, such as intrinsic reflection profiles and *Pendellösung*. The development of X-ray topography led to developments of the theory for spherical waves and for deformed crystals, with the hope of bridging the gap between the diffraction theories for perfect and 'ideally imperfect' crystals. The range of practical applications, from the characterization of the nature and properties of extended crystal defects to the study of crystal surfaces and to interferometry, became extremely wide.

Dynamical theory's third stage of life started with the arrival of the third-generation synchrotron-radiation sources, which opened up entirely new possibilities. The high brightness, low divergence, tunability and spatial coherence of the new sources opened the way for a myriad of new experiments. Many of them, as well as all the optical devices designed to condition the beam, take advantage of the possibilities offered by dynamical diffraction.

The dynamical theory is entirely based on Maxwell's theory of electromagnetism. It rests on a number of restricting hypotheses, some of which have been waived later by subsequent theories, but it is quite remarkable that no flaw has ever been found in its fundamentals and that it is still valid and in use today, 100 years after the discovery of X-ray diffraction.

AA thanks Helmut Klapper and Wolfgang Schmahl for their critical reading of the manuscript.

References

- Authier, A. (1960). *C. R. Acad. Sci. Paris*, **251**, 2003–2005.
 Authier, A. (1961). *Bull. Soc. Fr. Minér. Cristallogr.* **84**, 51–89.
 Authier, A. (2001). *Dynamical Theory of X-ray Diffraction*. (3rd ed. 2005.) Oxford University Press.
 Authier, A. (2003). *J. Phys. D Appl. Phys.* **36**, 1–4.
 Authier, A. (2009). *Acta Cryst.* **A65**, 167–182.
 Authier, A. (2012). *The Early Days of X-ray Diffraction*. Oxford University Press. In preparation.
 Authier, A. & Klapper, H. (2007). *Phys. Status Solidi A*, **204**, 2515–2527.
 Authier, A., Lagomarsino, S. & Tanner, B. K. (1996). Editors. *X-ray and Neutron Dynamical Diffraction: Theory and Applications*. NATO ASI Series, B: Physics. New York: Plenum Press/Kluwer Academic Publishers.
 Barkla, C. G. (1905). *Philos. Trans. R. Soc. London Ser. A*, **204**, 467–479.
 Barkla, C. G. (1906). *Proc. R. Soc. London Ser. A*, **77**, 247–255.
 Barkla, C. G. (1916). *Philos. Mag. Series 6*, **31**, 257–260.
 Bassler, E. (1909). *Ann. Phys.* **28**, 808–884.
 Batterman, B. W. (1964). *Phys. Rev. A*, **133**, 759–764.
 Batterman, B. W. (1969). *Phys. Rev. Lett.* **22**, 1354–1356.
 Bloch, F. (1928). *Z. Phys.* **52**, 555–600.
 Bonse, U. (1958). *Z. Phys.* **153**, 278–296.
 Bonse, U. & Hart, M. (1965). *Z. Phys.* **188**, 154–164.
 Bonse, U. & Hellkötter, H. (1969). *Z. Phys.* **223**, 345–352.
 Borrmann, G. (1935). *Naturwissenschaften*, **23**, 591–592.
 Borrmann, G. (1936). *Ann. Phys.* **27**, 669–693.
 Borrmann, G. (1938). *Z. Kristallogr.* **100**, 229–238.
 Borrmann, G. (1941). *Phys. Z.* **42**, 157–162.
 Borrmann, G. (1950). *Z. Phys.* **127**, 297–323.
 Borrmann, G. (1954). *Z. Kristallogr.* **106**, 109–121.
 Borrmann, G. (1955). *Naturwissenschaften*, **42**, 67–68.
 Borrmann, G. (1959a). *Beitr. Phys. Chem. 20 Jhd.* pp. 262–282. Braunschweig: Vieweg & Sohn.
 Borrmann, G. (1959b). *Phys. Bl.* **15**, 508–509.
 Borrmann, G., Hartwig, W. & Irmeler, H. (1958). *Z. Naturforsch.* **13a**, 423–425.
 Borrmann, G., Hildebrandt, G. & Wagner, H. (1955). *Z. Phys.* **142**, 406–414.
 Bowen, D. K. & Tanner, B. K. (1998). *High Resolution X-ray Diffraction and Topography*. London: Taylor and Francis Ltd.
 Bragg, W. H. (1907). *Philos. Mag. Series 6*, **14**, 429–449.
 Bragg, W. H. (1912a). *Nature (London)*, **90**, p. 219.
 Bragg, W. H. (1912b). *Nature (London)*, **90**, 360–361.
 Bragg, W. H. (1913). *Nature (London)*, **90**, p. 572.
 Bragg, W. H. (1915). *Philos. Trans. R. Soc.* **215**, 253–274.
 Bragg, W. H. & Bragg, W. L. (1913). *Proc. R. Soc. London Ser. A*, **88**, 428–438.
 Bragg, W. L. (1912). *Nature (London)*, **90**, p. 410.
 Bragg, W. L. (1913). *Proc. Cambridge Philos. Soc.* **17**, 43–57.
 Bragg, W. L., Darwin, C. G. & James, R. W. (1926). *Philos. Mag. Series 7*, **1**, 897–922.
 Bragg, W. L., James, R. W. & Bosanquet, C. H. (1921a). *Philos. Mag. Series 6*, **41**, 309–337.
 Bragg, W. L., James, R. W. & Bosanquet, C. H. (1921b). *Philos. Mag. Series 6*, **42**, 1–17.
 Bragg, W. L., James, R. W. & Bosanquet, C. H. (1922). *Philos. Mag. Series 6*, **44**, 433–449.
 Bravais, A. (1850). *J. Ec. Polytech.* **19**, 1–128.
 Bravais, A. (1851). *J. Ec. Polytech.* **20**, 101–276.
 Bullough, R. K. & Hynne, F. (1992). *Ewald's optical extinction theorem*. In P. P. Ewald and his Dynamical Theory of X-ray Diffraction, edited by D. W. J. Cruickshank, H. J. Juretschke and N. Kato, pp. 98–110. Oxford University Press.
 Clark, G. L. & Duane, W. (1923). *Proc. Natl Acad. Sci. USA*, **9**, 126–130.
 Compton, A. H. (1915). *Nature (London)*, **95**, 343–344.
 Compton, A. H. (1917). *Phys. Rev.* **9**, 29–57.
 Compton, A. H. (1922). *Phys. Rev.* **20**, p. 84.
 Compton, A. H. (1923a). *Philos. Mag. Series 6*, **45**, 1121–1131.
 Compton, A. H. (1923b). *Phys. Rev.* **21**, 483–502.
 Creagh, D. C. & Hart, M. (1970). *Phys. Status Solidi B*, **37**, 753–758.
 Cruickshank, D. W. J., Juretschke, H. J. & Kato, N. (1992). Editors. *P. P. Ewald and his Dynamical Theory of X-ray Diffraction*. Oxford University Press.
 Darwin, C. G. (1914a). *Philos. Mag. Series 6*, **27**, 315–333.
 Darwin, C. G. (1914b). *Philos. Mag. Series 6*, **27**, 675–690.
 Darwin, C. G. (1922). *Philos. Mag. Series 6*, **46**, 800–829.
 Davis, B. & Slack, C. M. (1925). *Phys. Rev.* **25**, 881–882.
 Davis, B. & Slack, C. M. (1926). *Phys. Rev.* **27**, 18–22.
 Davis, B. & Stempel, W. M. (1921). *Phys. Rev.* **17**, 608–623.

- Davis, B. & Terrill, H. M. (1922). *Proc. Natl Acad. Sci. USA*, **8**, 357–361.
- Debye, P. (1913). *Ann. Phys.* **43**, 49–95.
- Duane, W. & Patterson, R. A. (1920). *Phys. Rev.* **16**, 526–539.
- Eckert, M. (2012). *Acta Cryst.* **A68**, 30–39.
- Ewald, P. P. (1912). *Dispersion und Doppelbrechung von Elektronengittern*. Inaugural-Dissertation zur Erlangung der Doktorwürde, Königl. Ludwigs-Maximilians-Universität zu München (16 February 1912).
- Ewald, P. P. (1913). *Phys. Z.* **14**, 465–472.
- Ewald, P. P. (1916a). *Ann. Phys.* **49**, 1–38.
- Ewald, P. P. (1916b). *Ann. Phys.* **49**, 117–173.
- Ewald, P. P. (1917). *Ann. Phys.* **54**, 519–556.
- Ewald, P. P. (1920). *Z. Phys.* **2**, 332–342.
- Ewald, P. P. (1924). *Z. Phys.* **30**, 1–13.
- Ewald, P. P. (1927). *Handbuch der Physik*, Vol. 24, pp. 191–369. Berlin: Springer.
- Ewald, P. P. (1937). *Z. Kristallogr.* **97**, 1–27.
- Ewald, P. P. (1958). *Acta Cryst.* **11**, 888–891.
- Ewald, P. P. (1962). *Fifty Years of X-ray Diffraction*. Published for the International Union of Crystallography. Utrecht: N. V. A. Oosthoek.
- Ewald, P. P. (1968). *Acta Cryst.* **A24**, 1–3.
- Ewald, P. P. (1979). *Acta Cryst.* **A35**, 1–9.
- Friedrich, W., Knipping, P. & Laue, M. (1912). *Sitzungsber. K. Bayer. Akad. Wiss.* pp. 303–322.
- Gibbs, J. M. (1881). *Elements of Vector Analysis, Arranged for the Use of Students in Physics*. New Haven: Privately printed.
- Haga, H. & Wind, C. H. (1899). *Proc. R. Neth. Acad. (KNAW)*, **1**, 420–426.
- Haga, H. & Wind, C. H. (1902). *Proc. R. Neth. Acad. (KNAW)*, **5**, 247–254.
- Hatley, C. C. (1924). *Phys. Rev.* **24**, 486–494.
- Hildebrandt, G. (1993). *Cryst. Res. Technol.* **28**, 747–766.
- Hildebrandt, G. (1995). *J. Phys. D Appl. Phys.* **28**, A8–A16.
- Hildebrandt, G. (2002). *Cryst. Res. Technol.* **37**, 777–782.
- Hjalmar, E. (1920). *Z. Phys.* **1**, 439–458.
- Hjalmar, E. (1923). *Z. Phys.* **15**, 65–109.
- Hönl, H. (1933). *Z. Phys.* **84**, 1–16.
- James, R. W. (1962). *Early work on crystal structures at Manchester. In Fifty Years of X-ray Diffraction*, edited by P. P. Ewald. Published for the International Union of Crystallography. Utrecht: N. V. A. Oosthoek.
- James, R. W., Waller, I. & Hartree, D. R. (1928). *Proc. R. Soc. London*, **118**, 334–350.
- Kato, N. (1958). *Acta Cryst.* **11**, 885–887.
- Kato, N. (1960). *Acta Cryst.* **13**, 349–356.
- Kato, N. & Lang, A. R. (1959). *Acta Cryst.* **12**, 787–794.
- Klapper, H. (1991). *X-ray topography of organic crystals*. In *Crystals: Growth, Properties and Applications*, Vol. 13, edited by N. Karl, pp. 109–162. Berlin: Springer-Verlag.
- Koch, P. P. (1912). *Ann. Phys.* **38**, 507–522.
- Kohra, K., Kikuta, S. & Nakano, S. (1965). *J. Phys. Soc. Jpn*, **20**, 1959–1960.
- Kossel, W. (1924). *Z. Phys.* **23**, 278–285.
- Kossel, W., Loeck, H. & Voges, H. (1935). *Z. Phys.* **94**, 139–144.
- Kossel, W. & Voges, H. (1935). *Ann. Phys.* **23**, 677–704.
- Kubbinga, H. (2012). *Acta Cryst.* **A68**, 3–29.
- Lang, A. R. (1958). *J. Appl. Phys.* **29**, 597–598.
- Larsson, A., Siegbahn, M. & Waller, I. (1924). *Naturwissenschaften*, **52**, 1212–1213.
- Larsson, A., Siegbahn, M. & Waller, I. (1925). *Phys. Rev.* **25**, p. 235.
- Laue, M. von (1912). *Sitzungsber. K. Bayer. Akad. Wiss.* pp. 363–373.
- Laue, M. von (1914). *Jahrb. Radioakt. Elektron.* **11**, 308–345.
- Laue, M. von (1915). *Wellenoptik*. In *Enzykl. d. Math. Wiss.*, edited by A. Sommerfeld. Leipzig: B. G. Teubner.
- Laue, M. von (1931a). *Ergeb. Exakt. Naturwiss.* **10**, 133–158.
- Laue, M. von (1931b). *Naturwissenschaften*, **19**, p. 966.
- Laue, M. von (1935). *Naturwissenschaften*, **23**, p. 373.
- Laue, M. von (1940). *Naturwissenschaften*, **28**, 645–646.
- Laue, M. von (1941). *Röntgenstrahl-Interferenzen*. Leipzig: Akademische Verlagsgesellschaft, Beckert and Erler Komandit-Gesellschaft.
- Laue, M. von (1949). *Acta Cryst.* **2**, 106–113.
- Laue, M. von (1952a). *Acta Cryst.* **5**, 619–625.
- Laue, M. von (1952b). *Mein physikalischer Werdegang. Eine Selbstdarstellung*. Bonn. In *Schöpfer des neuen Weltbildes*, edited by H. Hartmann. Athenäum-V.
- Laue, M. von (1960). *Röntgenstrahl-Interferenzen*. Frankfurt Am Main: Akademische Verlagsgesellschaft.
- Lodge, O. (1896). *Electrician*, **37**, 370–373.
- Lohr, E. (1924). *Sitzungsber. Akad. Wiss. Wien*, **133**, 517–572.
- Lorentz, H. A. (1916). *The Theory of Electrons and its Applications to the Theory of Light and Radiant Heat*. Leipzig: B. G. Teubner.
- Malgrange, C. & Authier, A. (1965). *C. R. Acad. Sci. Paris*, **261**, 3774–3777.
- Malgrange, C., Velu, E. & Authier, A. (1968). *J. Appl. Cryst.* **1**, 181–184.
- Moliere, G. (1939a). *Ann. Phys.* **35**, 272–313.
- Moliere, G. (1939b). *Ann. Phys.* **36**, 265–274.
- Moseley, H. G. J. & Darwin, C. G. (1913a). *Nature (London)*, **90**, 594–694.
- Moseley, H. G. J. & Darwin, C. G. (1913b). *Philos. Mag. Series 6*, **26**, 210–232.
- Murdock, C. C. (1934). *Phys. Rev.* **45**, 117–118.
- Nardroff, R. von (1924). *Phys. Rev.* **24**, 143–151.
- Newkirk, J. B. (1958). *Phys. Rev.* **110**, 1465–1466.
- Okkerse, B. (1963). *Philips Res. Rep.* **18**, 413–431.
- Perrin, J. (1896). *C. R. Acad. Sci. Paris*, **122**, 186–188.
- Prins, J. A. (1930). *Z. Phys.* **63**, 477–493.
- Raman, C. V. (1937). *Laue diagrams, 25 years of research on X-ray diffraction following Prof. Max von Laue's Discovery*. In *Current Science*, pp. 1–2. Bangalore: Indian Academy of Science.
- Renninger, M. (1934). *Z. Kristallogr.* **89**, 344–374.
- Renninger, M. (1955). *Acta Cryst.* **8**, 597–606.
- Röntgen, W. C. (1895). *Sitzungsber. Würzburger Phys. Med. Ges.* **137**, 132–141. Translated into English by A. Stanton (1896). *Nature (London)*, **53**, 274–276. (23 January 1896.)
- Röntgen, W. C. (1896). *Sitzungsber. Würzburger Phys. Med. Ges.* **138**, 1–11.
- Röntgen, W. C. (1898). *Ann. Phys.* **64**, 18–37.
- Rutherford, E. & Andrade, E. N. da C. (1914). *Philos. Mag. Series 6*, **28**, 263–273.
- Schülke, W. & Brümmer, O. (1962). *Z. Naturforsch. Teil A*, **17**, 208–216.
- Siegbahn, M. (1919). *Ann. Phys.* **59**, 56–72.
- Sommerfeld, A. (1900). *Phys. Z.* **2**, 55–60.
- Sommerfeld, A. (1912). *Ann. Phys.* **38**, 473–506.
- Stark, J. (1907). *Phys. Z.* **8**, 881–884.
- Stenström, W. (1919). *Experimentelle Untersuchungen der Röntgenspectra*. Lund: Dissertation.
- Stokes, G. G. (1849). *Trans. Cambridge Philos. Soc.* **8**, 1–62.
- Stokes, G. G. Sir (1896). *Proc. Cambridge Philos. Soc.* **9**, 215–216.
- Stokes, G. G. Sir (1897). *Mem. Proc. Manchester Lit. Philos. Soc.* **41**, 43–66.
- Takagi, S. (1962). *Acta Cryst.* **15**, 1311–1312.
- Takagi, S. (1969). *J. Phys. Soc. Jpn*, **26**, 1239–1253.
- Thomson, J. J. (1898). *Philos. Mag. Series 5*, **45**, 172–183.
- Thomson, J. J. (1903). *Conduction of Electricity Through Gases*. Cambridge University Press.
- Vartanyants, I. A. & Koval'chuk, M. V. (2001). *Rep. Prog. Phys.* **64**, 1009–1084.
- Voges, H. (1936). *Ann. Phys.* **27**, 694–720.

Wagenfeld, H. (1968). *Acta Cryst.* **A24**, 170–174.

Walter, B. & Pohl, R. (1908). *Ann. Phys.* **25**, 715–724.

Walter, B. & Pohl, R. (1909). *Ann. Phys.* **29**, 331–354.

Wheaton, B. R. (1983). *The Tiger and the Shark. Empirical Roots of*

the Wave–Particle Dualism. Cambridge University Press.

Wiechert, E. (1896). *Schr. Phys. Ökon. Ges. Königsberg*, **37**, 1–48.

Wien, W. (1907). *Nachr. Kgl. Ges. Wiss. Göttingen*, **5**, 598–601.

Zegenhagen, J. (1993). *Surf. Sci. Rep.* **18**, 199–271.